

Flanged Swing Check Valve With Counter Weight PN16

- Designed to BS5153
- Complies to SANS 1551-2 2007
- SG Iron Body
- EPDM Encapsulated SG Iron Gate with Stainless Steel Swing Arm
- With Counter Weight Lever
- NBR Encapsulated Gate on request
- Coating: FBE – 250 Micron (Signal Blue)
- PN16

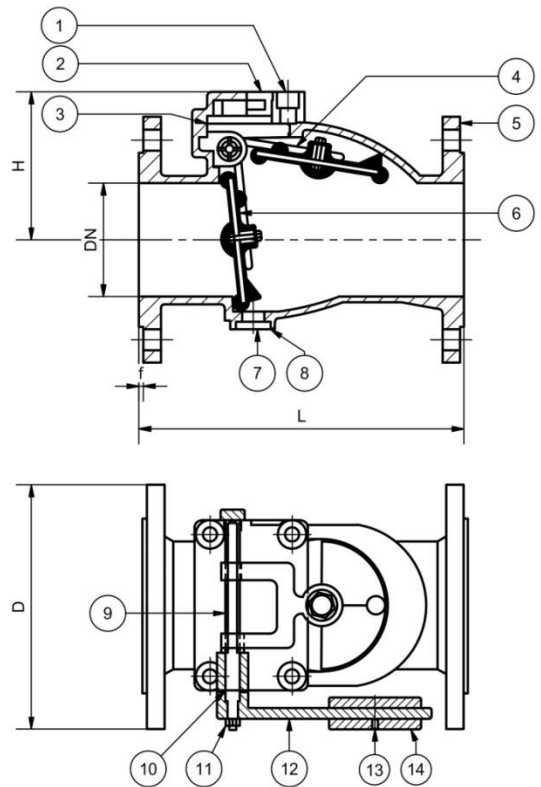

Material List		
Item	Part	Material
1	Cap Screw	HT Steel - Grd 8.8
2	Bonnet	SG Iron - Grd 420/12
3	O-Ring	NBR / EPDM
4	Swing Arm	Stainless Steel - Grd 304
5	Body	SG Iron - Grd 420/12 – FBE
6	Gate	EPDM Encapsulated SG Iron
7	Drain Plug	Brass
8	O-Ring	NBR / EPDM
9	Hanger Pin	Stainless Steel - Grd 410
10	Split Pin	Stainless Steel - Grd 304
11	Nut	Mild Steel – Grd 8.1
12	Counter Weight Lever	Mild Steel FBE Coated
13	Adjustment Screw	Mild Steel – Grd 8.1
14	Counter Weight	Mild Steel FBE Coated



Dimensions						
DN	L	D	b	f	H	Mass (kg)
50	203	165	19	3	100	12
80	241	200	19	3	130	16
100	292	220	19	3	140	19
150	356	285	19	3	195	35
200	495	340	20	3	213	59
250	622	405	25	3	265	95
300	698	485	28	4	295	130