

Indicator with single window, Toughened glass, Screwed Female BSP ends.

- Max. Steam Working Pressure: 15.30 Kg/Cm² (218 Psig)
- Maximum Permissible Temp: 225°C (437° F)
- Hydraulic Test Pressure: 30.58 Kg/Cm² (435 Psig).

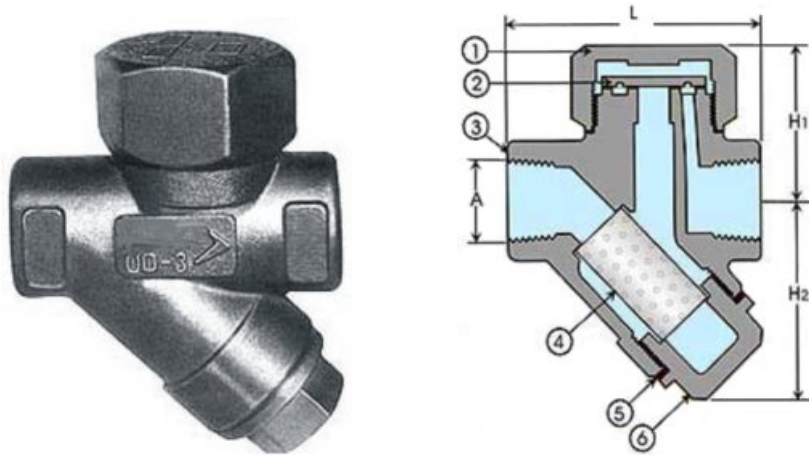

MATERIALS			
Part No.	Name of Part	Material	Specifications
1	Top Cover	Stainless Steel	ASTM-A 743 Gr CA 15
2	Disc	Stainless Steel	ASTM-A 743 Gr CA 15
3	Body	Stainless Steel	ASTM-A 743 Gr CA 15
4	Strainer	Stainless Steel	AISI-304
5	Gasket	CAF	IS:2712 Gr W/1
6	Bottom Cover	Stainless Steel	ASTM-A 743 Gr CA 15

DIMENSIONS					
Nominal Size		A	L	H ₁	H ₂
Inch	MM				
1/2"	15	1/2" BSPT	78	44	60
3/4"	20	3/4" BSPT	78	44	60
1"	25	1" BSPT	84	54	70